



**PET PREFORM SPECIFICATIONS SHEET**

DATE: Feb 12 th, 16

REFERENCE: PRE-KX-01

MADE BY: PET LABORATORY

REV: "0"

**TECHNICAL SHEET: 51.5 PCO 1816 PREFORM**

<b>PREFORM:</b> 51.5	<b>FINISH:</b> PCO 1816	<b>COLOR:</b> WITHOUT COLOR, PIGMENTED, CLEAR, OR OPAQUE
<b>COMPOSITION:</b>	PET RESIN (POLYETHYLENE TEREPHTHALATE) WITH OR WITHOUT PIGMENT	
<b>INTENDED USE:</b>	MANUFACTURE OF PACKAGING	
<b>PACKING:</b>	GAYLORD CONTAINER (CARTON BULK BOX), STRAPPED AND LABELED, POLYETHYLENE INNER LINER.	<b>PIECES PER BOX:</b> 5,808
<b>STORAGE:</b>	DO NOT EXPOSE THE BOX TO MOISTURE, UV RAYS, AVOID BRUSH MOVEMENTS KEEP IN CLEAN PLACE, WITHOUT DUST.	

**QUALITY LABORATORY TESTS:** WEIGHT, DIMENSIONAL ANALYSIS, ACETALDEHYDE AND INTRINSEC VISCOSITY.

**DIMENSIONS:**

No.	CHARACTERISTIC	UNITS	SPECIFICATIONS	
			MIN	MAX
1	WEIGHT	g	51.06	51.66
2	CONTROL DIAMETER AT TOP OF FINISH	mm	21.61	21.87
3	THREAD ROOT DIAMETER	mm	24.36	24.66
4	THREAD CREST DIAMETER	mm	27.30	27.56
5	TAMPER EVIDENT BEAD DIAMETER	mm	27.84	28.10
6	SUPPORT LEDGE DIAMETER	mm	32.62	33.38
7	HEIGHT FROM SUPPORT LEDGE	mm	21.00	21.40
8	THICKNESS 1	mm	3.53	3.79
9	THICKNESS 2	mm	3.53	3.79
10	THICKNESS 3	mm	3.53	3.79
11	THICKNESS 4	mm	3.53	3.79
12	TOTAL PREFORM HEIGHT	mm	152.10	152.50

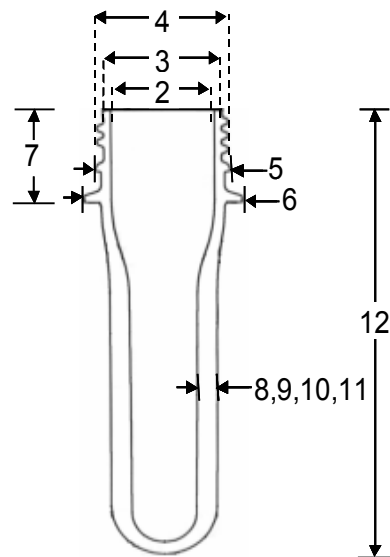

NOTE: THICKNESS 1, 2, 3 AND 4 ARE 90° EACH OTHER.  
HEIGHT FROM SUPPORT LEDGE = HEIGHT OF FINISH