



Éxito a través del Servicio

KIMEX PET S.A. DE C.V.

KM. 26.5 AUTOPISTA MEXICO-QUERETARO

APARTADO POSTAL No. 168 TLALNEPANTLA,

ESTADO DE MEXICO, C.P. 54020 MEXICO

TELS: 53-66-90-00



PET PREFORM SPECIFICATIONS SHEET

DATE: Feb 12 th, 17

REFERENCE: PRE-KX-01

MADE BY: PET LABORATORY

REV: "O"

TECHNICAL SHEET: 24.5 PCO 1881 PREFORM

PREFORM: 24.5

FINISH: PCO 1881

COLOR: WITHOUT COLOR, PIGMENTED, CLEAR, OR OPAQUE

COMPOSITION:

PET RESIN (POLYETHYLENE TEREPHTHALATE) WITH OR WITHOUT PIGMENT

INTENDED USE:

MANUFACTURE OF PACKAGING

PACKING:

GAYLORD CONTAINER (CARTON BULK BOX), STRAPPED AND LABELED, POLYETHYLENE INNER LINER.

PIECES PER BOX: 12,816

STORAGE:

DO NOT EXPOSE THE BOX TO MOISTURE, UV RAYS, AVOID BRUSH MOVEMENTS KEEP IN CLEAN PLACE, WITHOUT DUST.

QUALITY LABORATORY TESTS:

WEIGHT, DIMENSIONAL ANALYSIS, ACETALDEHYDE AND INTRINSEC VISCOSITY.

DIMENSIONS:

No.	CHARACTERISTIC	UNITS	SPECIFICATIONS	
			MIN	MAX
1	WEIGHT	g	24.27	24.87
2	CONTROL DIAMETER AT TOP OF FINISH	mm	21.61	21.87
3	THREAD ROOT DIAMETER	mm	24.07	24.33
4	THREAD CREST DIAMETER	mm	27.27	27.53
5	TAMPER EVIDENT BEAD DIAMETER	mm	27.85	28.15
6	SUPPORT LEDGE DIAMETER	mm	32.85	33.15
7	HEIGHT FROM SUPPORT LEDGE	mm	16.75	17.25
8	THICKNESS 1	mm	3.34	3.60
9	THICKNESS 2	mm	3.34	3.60
10	THICKNESS 3	mm	3.34	3.60
11	THICKNESS 4	mm	3.34	3.60
12	TOTAL PREFORM HEIGHT	mm	97.67	98.07

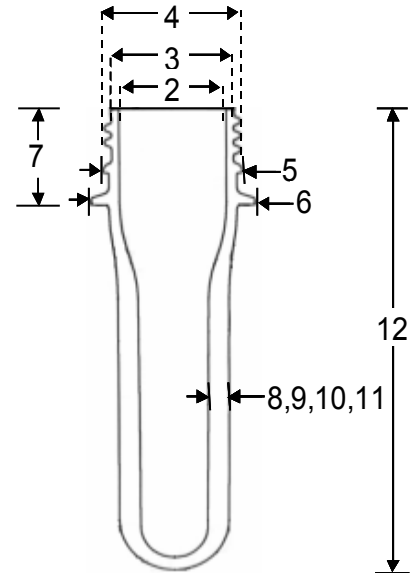

NOTE: THICKNESS 1, 2, 3 Y 4 ARE 90° EACH OTHER.

HEIGHT FROM SUPPORT LEDGE = HEIGHT OF FINISH