



Éxito a través del Servicio

KIMEX PET S.A. DE C.V.

KM. 26.5 AUTOPISTA MEXICO-QUERETARO

APARTADO POSTAL No. 168 TLALNEPANTLA,

ESTADO DE MEXICO, C.P. 54020 MEXICO

TELS: 53-66-90-00



**PET PREFORM SPECIFICATIONS SHEET**

DATE: Feb 12 th, 16

REFERENCE: PRE-KX-01

MADE BY: PET LABORATORY

REV: "0"

**TECHNICAL SHEET: 37 PCO 1881 PREFORM**

<b>PREFORM:</b> 37	<b>FINISH:</b> PCO 1881	<b>COLOR:</b> WITHOUT COLOR, PIGMENTED, CLEAR, OR OPAQUE
<b>COMPOSITION:</b>	PET RESIN (POLYETHYLENE TEREPHTHALATE) WITH OR WITHOUT PIGMENT	
<b>INTENDED USE:</b>	MANUFACTURE OF PACKAGING	
<b>PACKING:</b>	GAYLORD CONTAINER (CARTON BULK BOX), STRAPPED AND LABELED, POLYETHYLENE INNER LINER.	<b>PIECES PER BOX:</b> 9,120
<b>STORAGE:</b>	DO NOT EXPOSE THE BOX TO MOISTURE, UV RAYS, AVOID BRUSH MOVEMENTS KEEP IN CLEAN PLACE, WITHOUT DUST.	

**QUALITY LABORATORY TESTS:** WEIGHT, DIMENSIONAL ANALYSIS, ACETALDEHYDE AND INTRINSEC VISCOSITY.

**DIMENSIONS:**

No.	CHARACTERISTIC	UNITS	SPECIFICATIONS	
			MIN	MAX
1	WEIGHT	g	36.12	36.72
2	CONTROL DIAMETER AT TOP OF FINISH	mm	21.61	21.87
3	THREAD ROOT DIAMETER	mm	24.07	24.33
4	THREAD CREST DIAMETER	mm	27.27	27.53
5	TAMPER EVIDENT BEAD DIAMETER	mm	27.85	28.15
6	SUPPORT LEDGE DIAMETER	mm	32.85	33.15
7	HEIGHT FROM SUPPORT LEDGE	mm	16.75	17.25
8	THICKNESS 1	mm	3.67	3.93
9	THICKNESS 2	mm	3.67	3.93
10	THICKNESS 3	mm	3.67	3.93
11	THICKNESS 4	mm	3.67	3.93
12	TOTAL PREFORM HEIGHT	mm	123.00	123.40

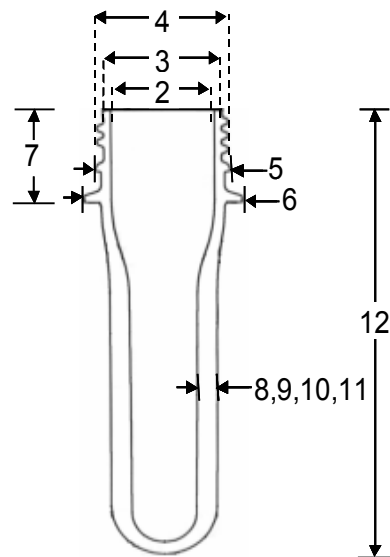

NOTE: THICKNESS 1, 2, 3 Y 4 ARE 90° EACH OTHER.  
HEIGHT FROM SUPPORT LEDGE = HEIGHT OF FINISH